

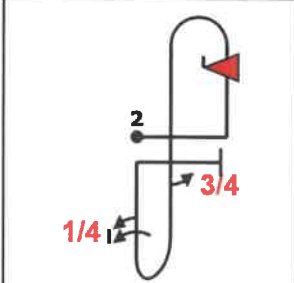









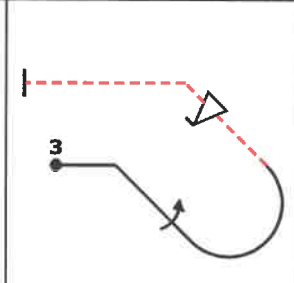

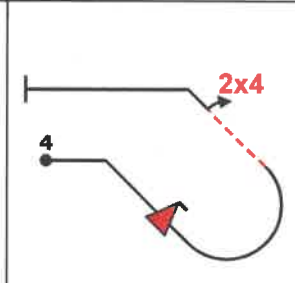

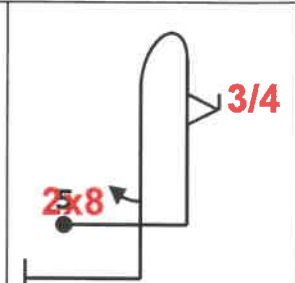

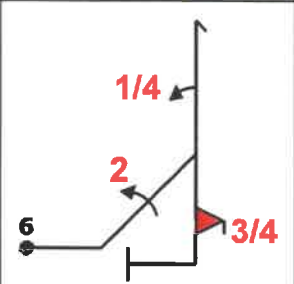
 <p>Fig A 7.4.3.2(19) 9.9.3.2(11) 9.4.3.2(5) K: 35</p> <p>GER</p> 	 <p>Fig B 8.8.2.1(19) 9.10.6.4(19) 9.1.5.3(6) 9.1.1.5(14) K: 58</p> <p>SUI</p> 	 <p>Fig C 8.4.17.3(11) 9.1.4.4(8) 9.9.7.4(15) K: 34</p> <p>POL</p> 	 <p>Fig D 8.4.18.3(13) 9.10.9.4(15) 9.4.2.2(7) K: 35</p> <p>CZE</p> 	 <p>Fig E 8.4.1.1(13) 9.9.1.3(15) 9.8.5.1(3) K: 31</p> <p>ITA</p> 
 <p>Fig F 5.3.1.1(18) 9.2.2.4(11) 9.1.1.1(6) 9.10.5.3(13) K: 48</p> <p>ROU</p> 	 <p>Fig G 8.5.1.1(12) 9.4.2.4(13) 9.8.3.1(3) 9.1.3.5(9) K: 37</p> <p>FRA</p> 	 <p>Fig H 8.6.6.2(15) 9.1.3.8(12) 9.8.3.4(15) 9.4.5.2(5) 9.1.5.2(4) K: 51</p> <p>RUS</p> 	 <p>Fig I 8.8.6.1(21) 9.4.1.3(12) 9.1.5.1(2) 9.4.1.2(9) K: 44</p> <p>HUN</p> 	 <p>Fig J 7.4.3.3(18) 9.8.3.2(7) 9.1.3.6(10) K: 35</p> <p>ESP</p> 

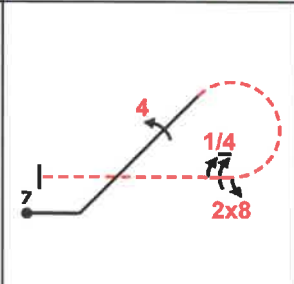
Pierre Vanhoren

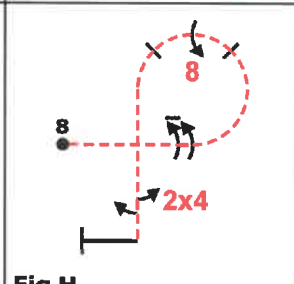

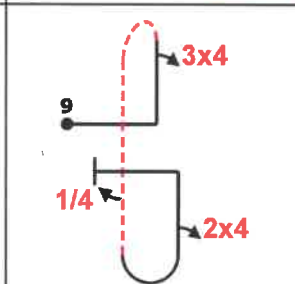

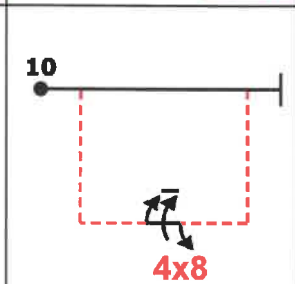
EAC 2018		A	Form B
Pilot ID	CIVA Unlimited Unknown2		Flight #

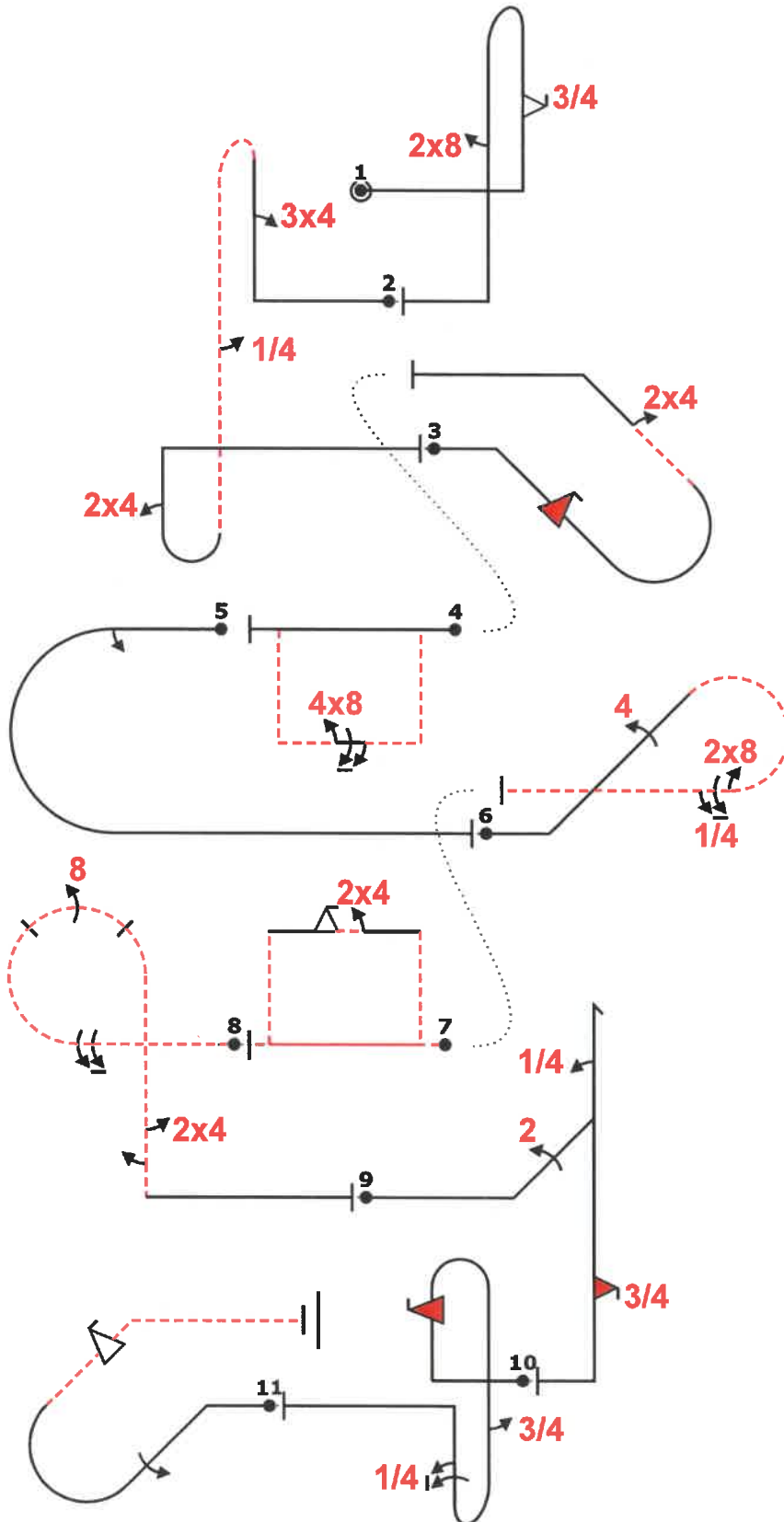

Power			
Fig 1 E	8.4.1.1	13	31 ✓
	9.9.1.3	15	
	9.8.5.1	3	
Fig 2 I	8.8.6.1	21	44 ✓
	9.4.1.3	12	
	9.1.5.1	2	
	9.4.1.2	9	
Fig 3 D	8.4.18.3	13	35 ✓
	9.10.9.4	15	
	9.4.2.2	7	
Fig 4 J	7.4.3.3	18	35 ✓
	9.8.3.2	7	
	9.1.3.6	10	
Fig 5 Add.	7.2.3.3	6	24 ✓
	9.1.3.2	4	
Fig 6 G	8.5.1.1	12	37 ✓
	9.4.2.4	13	
	9.8.3.1	3	
	9.1.3.5	9	
Fig 7 A	7.4.3.2	19	35 ✓
	9.9.3.2	11	
	9.4.3.2	5	
Fig 8 H	8.6.6.2	15	51 ✓
	9.1.3.8	12	
	9.8.3.4	15	
	9.4.5.2	5	
	9.1.5.2	4	
Fig 9 F	5.3.1.1	18	48 ✓
	9.2.2.4	11	
	9.1.1.1	6	
	9.10.5.3	13	
Fig 10 B	8.8.2.1	19	58 ✓
	9.10.6.4	19	
	9.1.5.3	6	
	9.1.1.5	14	
Fig 11 C	8.4.17.3	11	34 ✓
	9.1.4.4	8	
	9.9.7.4	15	
Total K = 432			

3 Sept 2018
 14:40
 Piene Ullatse

 OK

_____/ Pilot
/ A/C



Jindrichuv Hradec 3/9/18

B Form B

Pilot ID

CIVA Unlimited Programme3

Flight #

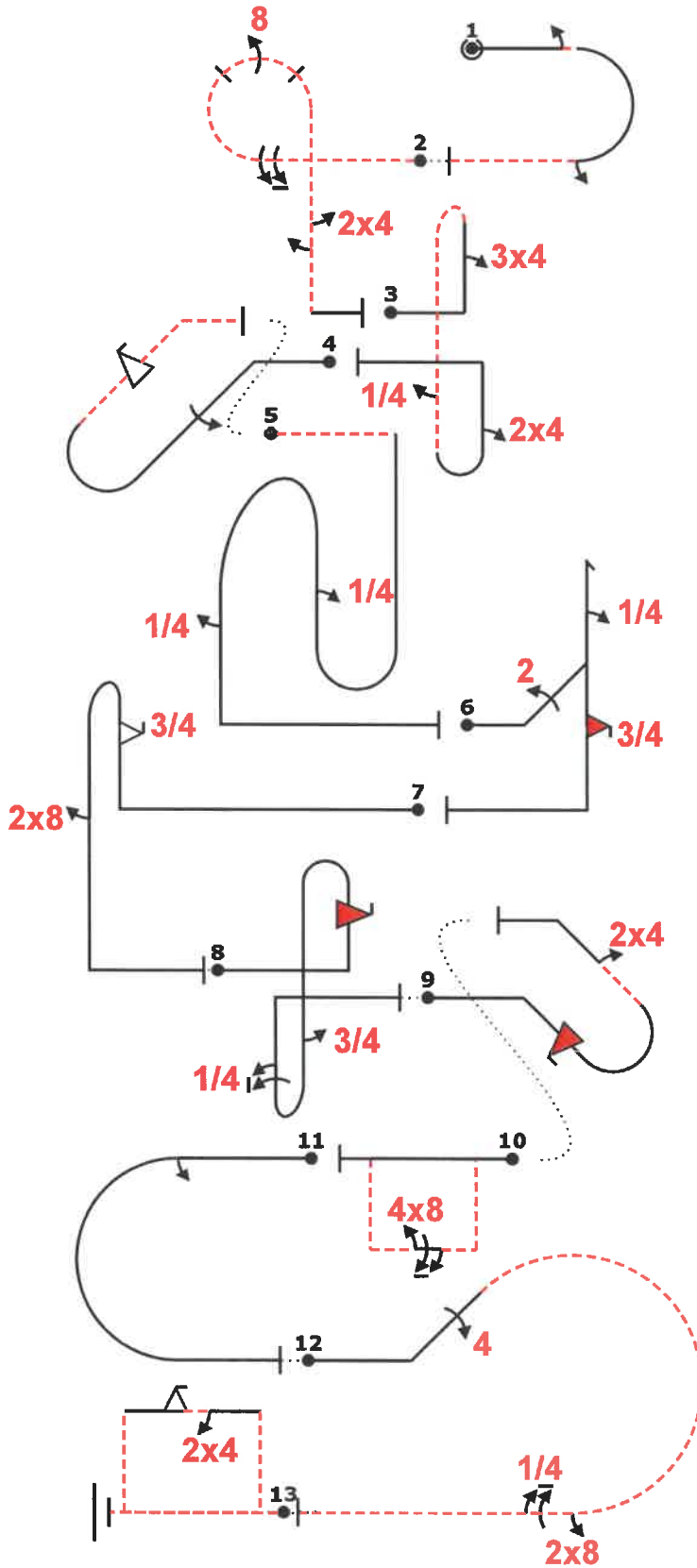

Power			
Fig 1 Add.	7.2.4.3	6	8 ✓
	9.1.3.2	4	
	9.1.3.2	4	
Fig 2 H	8.6.6.2	15	51 ✓
	9.1.3.8	12	
	9.8.3.4	15	
	9.4.5.2	5	
	9.1.5.2	4	
Fig 3 I	8.8.6.1	21	44 ✓
	9.4.1.3	12	
	9.1.5.1	2	
	9.4.1.2	9	
Fig 4 C	8.4.17.3	11	34 ✓
	9.1.4.4	8	
	9.9.7.4	15	
Fig 5 Add.	8.8.1.4	18	8 ✓
	9.1.1.1	6	
	9.1.5.1	2	
Fig 6 F	5.3.1.1	18	48 ✓
	9.2.2.4	11	
	9.1.1.1	6	
	9.10.5.3	13	
Fig 7 E	8.4.1.1	13	31 ✓
	9.9.1.3	15	
	9.8.5.1	3	
Fig 8 B	8.8.2.1	19	58 ✓
	9.10.6.4	19	
	9.1.5.3	6	
	9.1.1.5	14	
Fig 9 D	8.4.18.3	13	35 ✓
	9.10.9.4	15	
	9.4.2.2	7	
Fig 10 J	7.4.3.3	18	35 ✓
	9.8.3.2	7	
	9.1.3.6	10	
Fig 11 Add.	7.2.3.3	6	8 ✓
	9.1.3.2	4	
Fig 12 G	8.5.1.1	12	37 ✓
	9.4.2.4	13	
	9.8.3.1	3	
	9.1.3.5	9	
Fig 13 A	7.4.3.2	19	35 ✓
	9.9.3.2	11	
	9.4.3.2	5	
Total K = 432			

3 Sqf 2018
14:40
Pavel Valocsek
[Signature]
OK

"@L" '2'a2----- (2,0) -1% "@H" -9p(88)'24',2. -2% "@I" ,34''pbb(' ,4') ,24''+++ -3% "@C" +'1..'irdb'f,'-..... (-2,8) "@L" 4% -..'ibB(
.....,4') ,4'+++ -1% "@F" '22dh(,4)'31f.'+++ -1% "@E" ~++++,3fb'' ,8..' + (-3,0) -2% "@B" ~+if'bb('3)5''+++ (-2,0) -3% "@O" ~+ ,ifi
rdb,24.'+..... (5,17) -2% "@J" 'lqo48,6' "@L" 8% '2a (-2,0) "@G" 13% '+'..... ,44''rc8,5-..... (3,0) -1% "@A" -qo2f,24-

Pilot
A/C



Jindrichuv Hradec 2018		C	Form B
Pilot ID	CIVA Unlimited Unknown2		Flight #

← wind/vent

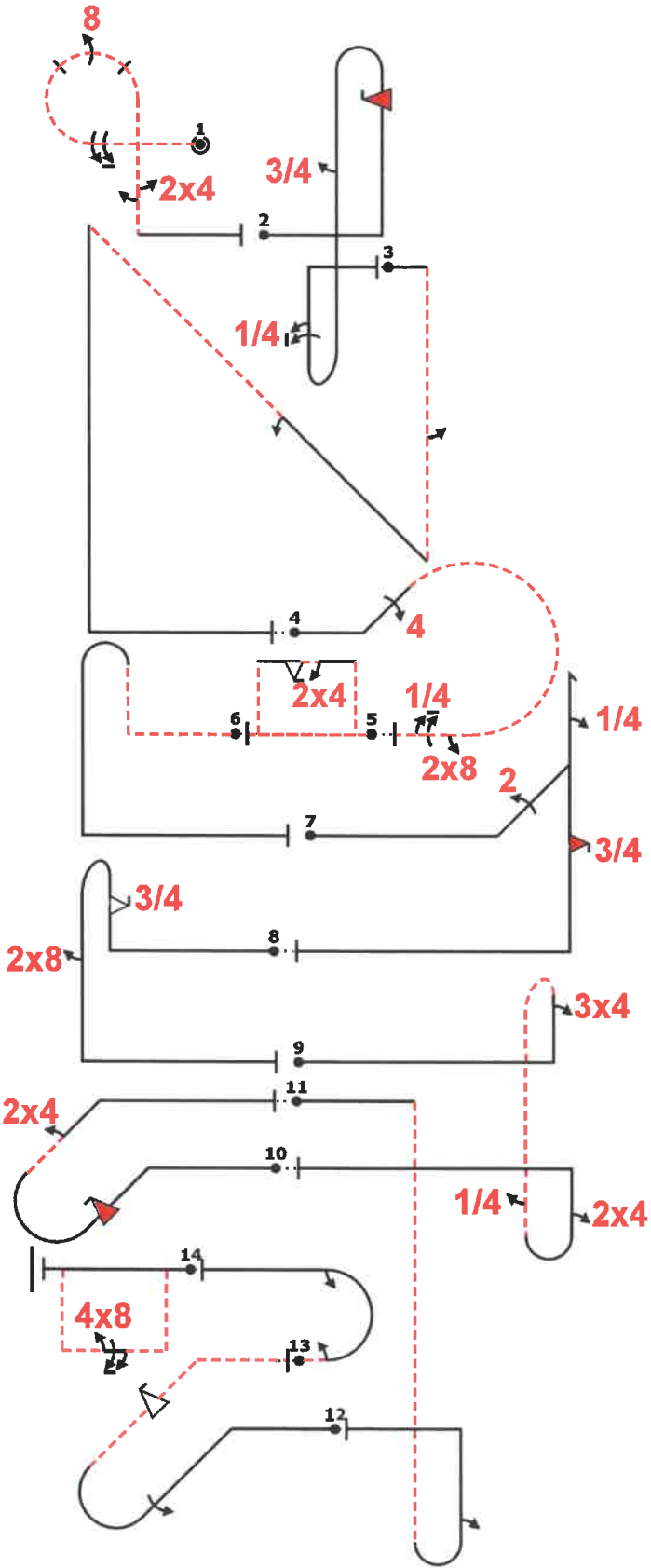

Power			
Fig 1 H	8.6.6.2	15	51 ✓
	9.1.3.8	12	
	9.8.3.4	15	
	9.4.5.2	5	
Fig 2 B	8.8.2.1	19	58 ✓
	9.10.6.4	19	
	9.1.5.3	6	
	9.1.1.5	14	
Fig 3 Add.	1.3.16.3	21	6 ✓
	9.1.5.2	4	
	9.1.2.2	6	
Fig 4 G	8.5.1.1	12	37 ✓
	9.4.2.4	13	
	9.8.3.1	3	
	9.1.3.5	9	
Fig 5 A	7.4.3.2	19	35 ✓
	9.9.3.2	11	
	9.4.3.2	5	
Fig 6 Add.	8.4.4.2	14	6 ✓
Fig 7 F	5.3.1.1	18	48 ✓
	9.2.2.4	11	
	9.1.1.1	6	
	9.10.5.3	13	
Fig 8 E	8.4.1.1	13	31 ✓
	9.9.1.3	15	
	9.8.5.1	3	
Fig 9 I	8.8.6.1	21	44 ✓
	9.4.1.3	12	
	9.1.5.1	2	
	9.4.1.2	9	
Fig 10 D	8.4.18.3	13	35 ✓
	9.10.9.4	15	
	9.4.2.2	7	
Fig 11 Add.	8.4.3.3	15	6 ✓
	9.1.1.2	8	
Fig 12 C	8.4.17.3	11	34 ✓
	9.1.4.4	8	
	9.9.7.4	15	
Fig 13 Add.	7.2.4.2	6	6 ✓
	9.1.3.2	4	
	9.1.3.2	4	
Fig 14 J	7.4.3.3	18	35 ✓
	9.8.3.2	7	
	9.1.3.6	10	
Total K = 432			

3 Sept 2018
16:40
Primo Valerietex

OK

ed "@H" -9p(88)24,2'~ " @B" ~+.. 'if'bb(' ,3....)'5' (-3,0) "@L" ~+... '2.' 'in(....'2.....'').....'++++ (-2,0) "@G" 9% '+'.....',44'
...rc'8,5-..... (2,0) "@A" -2% -qo,2f;24- (3,0) "@L" ~-... 'b.' '++++ "@F" +++22'dh(,4).3if.,++++~ (2,0) "@E" ~++++),3fb,8.' '++
+~ "@I" ~++++,34pb(....',4'),24+++++ (2,0) "@D" -1% ~++ ,ifirdb'24,~+~ (-2,0) "@L" ~+..... 'ib''',2.' +~ (3,0) "@C" -2% ~+...1irdb
'f.' ~- (-3,0) "@L" ~-2m2+++ (3,0) "@J" -1% iqo48,6

Pilot
A/C



D		Form B
Pilot ID	CIVA Unlimited Programme3	
	Flight #	

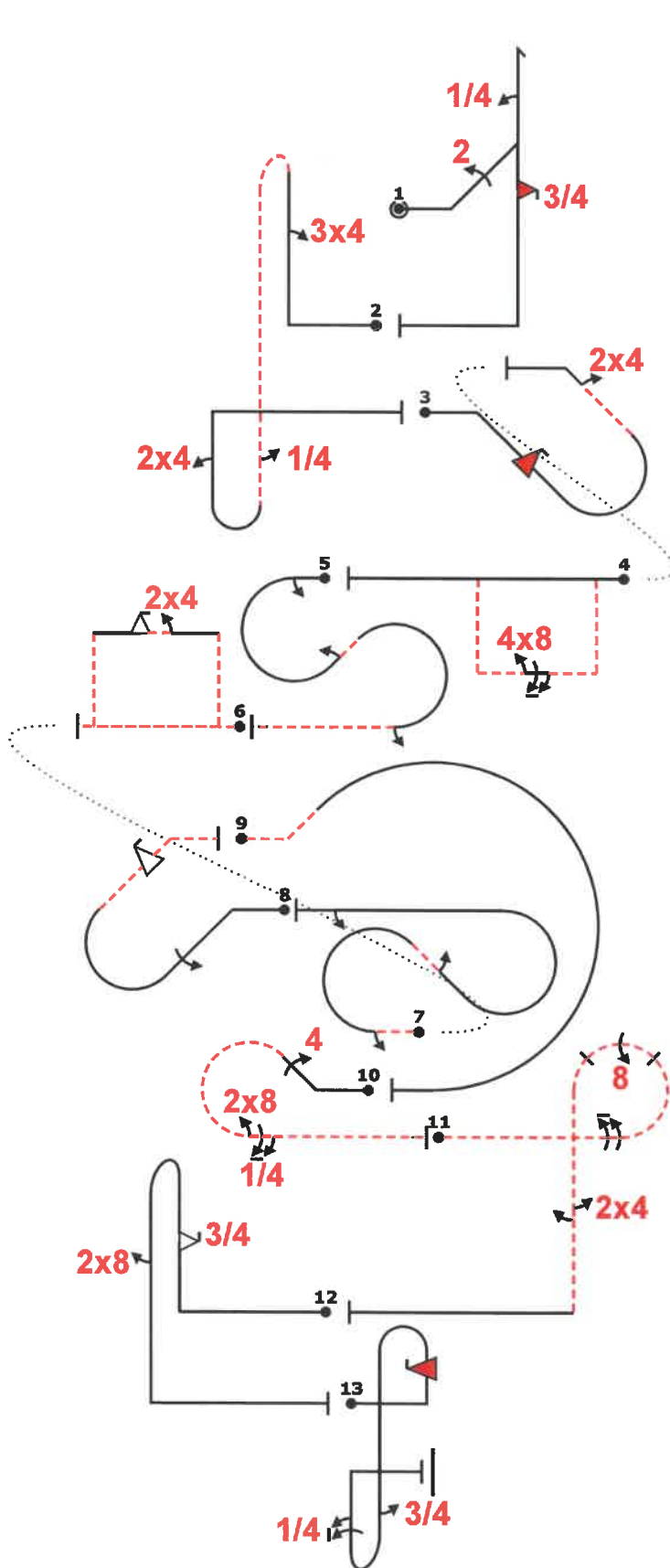

Power			
Fig 1 F	5.3.1.1 9.2.2.4 9.1.1.1 9.10.5.3	18 11 6 13	48 ✓
Fig 2 I	8.8.6.1 9.4.1.3 9.1.5.1 9.4.1.2	21 12 2 9	44 ✓
Fig 3 D	8.4.18.3 9.10.9.4 9.4.2.2	13 15 7	35 ✓
Fig 4 J	7.4.3.3 9.8.3.2 9.1.3.6	18 7 10	35 ✓
Fig 5 Add.	7.5.8.3 9.1.3.2 9.1.2.2 9.1.3.2	15 4 6 4	8 ✓
Fig 6 A	7.4.3.2 9.9.3.2 9.4.3.2	19 11 5	35 ✓
Fig 7 Add.	7.5.8.2 9.1.3.2 9.1.4.2 9.1.3.2	15 4 4 4	8 ✓
Fig 8 C	8.4.17.3 9.1.4.4 9.9.7.4	11 8 15	34 ✓
Fig 9 Add.	8.5.1.2	10	8 ✓
Fig 10 G	8.5.1.1 9.4.2.4 9.8.3.1 9.1.3.5	12 13 3 9	37 ✓
Fig 11 H	8.6.6.2 9.1.3.8 9.8.3.4 9.4.5.2 9.1.5.2	15 12 15 5 4	51 ✓
Fig 12 E	8.4.1.1 9.9.1.3 9.8.5.1	13 15 3	31 ✓
Fig 13 B	8.8.2.1 9.10.6.4 9.1.5.3 9.1.1.5	19 19 6 14	58 ✓
Total K = 432			

3 Sept 2018
14:40

Pierre Vachon
OK

"@F" 22dh(4)3if...++ "@I" ~.,34.'pbb(...'4)''24+++ "@0" if'irdb,24+... (14,18) "@J" iqa48,6+++ "@L" 1%2iac('2')2
(3,0) "@A" -qo2f;24- (33,26) "@L" 1%2ac(2)....'2+ (3,0) "@C" i1rdbf-... "@M" 25% "@N" 25%
rc+ "@G" ,44' rc8,5- (-3,0) "@H" ...9p(88)''24,2...++++ "@E" ++,3f.b,8...'++ "@B" ''fbb('3')5

Pilot
A/C



EAC 2018		E	Form B
Pilot ID	CIVA Unlimited Unknown2		Flight #

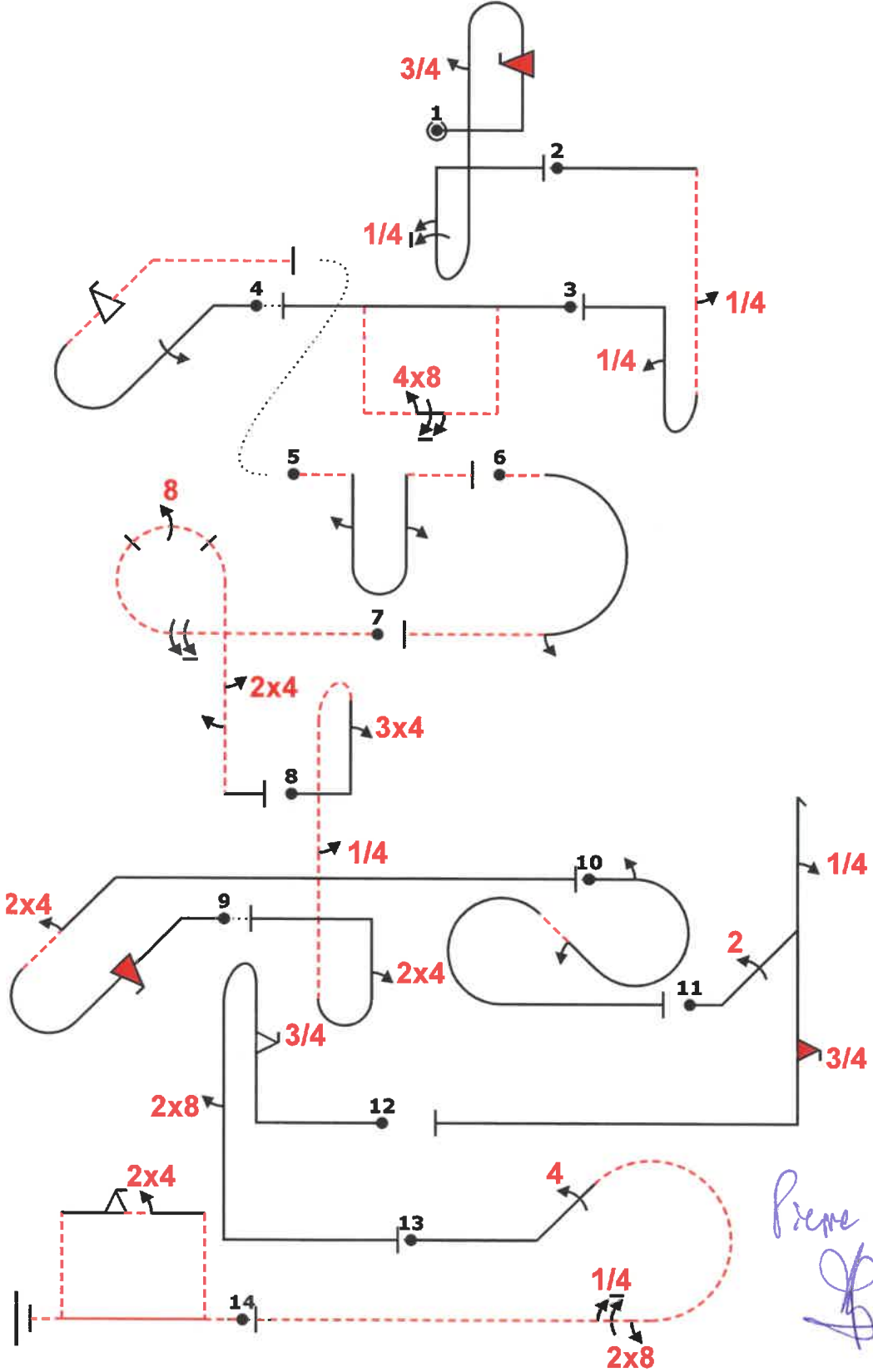

Power			
Fig 1 B	8.8.2.1	19	58 ✓
	9.10.6.4	19	
	9.1.5.3	6	
Fig 2 Add.	8.4.3.3	15	6 ✓
	9.1.5.1	2	
	9.1.1.1	6	
Fig 3 J	7.4.3.3	18	35 ✓
	9.8.3.2	7	
	9.1.3.6	10	
Fig 4 C	8.4.17.3	11	34 ✓
	9.1.4.4	8	
	9.9.7.4	15	
Fig 5 Add.	8.4.1.4	13	6 ✓
	9.1.5.2	4	
	9.1.1.2	8	
Fig 6 Add.	7.2.2.4	7	6 ✓
	9.1.3.2	4	
Fig 7 H	8.6.6.2	15	51 ✓
	9.1.3.8	12	
	9.8.3.4	15	
	9.4.5.2	5	
	9.1.5.2	4	
Fig 8 I	8.8.6.1	21	44 ✓
	9.4.1.3	12	
	9.1.5.1	2	
	9.4.1.2	9	
Fig 9 D	8.4.18.3	13	35 ✓
	9.10.9.4	15	
	9.4.2.2	7	
Fig 10 Add.	7.5.5.3	15	6 ✓
	9.1.3.2	4	
	9.1.2.2	6	
Fig 11 F	5.3.1.1	18	48 ✓
	9.2.2.4	11	
	9.1.1.1	6	
	9.10.5.3	13	
Fig 12 E	8.4.1.1	13	31 ✓
	9.9.1.3	15	
	9.8.5.1	3	
Fig 13 G	8.5.1.1	12	37 ✓
	9.4.2.4	13	
	9.8.3.1	3	
	9.1.3.5	9	
Fig 14 A	7.4.3.2	19	35 ✓
	9.9.3.2	11	
	9.4.3.2	5	
Total K = 432			

3 Sept 2013
14:40
Pierre Valois & Aux
OK

"@B" 1f'bb(.....,3...)5~ (-3,0) "@L" ~+.4.'1b'4 (3,0) "@J" +1q048,6~ (2,0) "@C" -3% '1.'irdbf.-- (-4,16) "@L"2'1b'.....2-
"@L" 5% --a2-- "@H" -.9p(88)24',2,+ "@I"+34'pbb(4..),24+ (2,0) "@D" -3% '1f.'irdb24.....+ (-3,0) "@L"
21ac(2)+ "@F"+22dh('4').'3if.+++++ (0,0) "@E" +,3f'b',.8..+ (-3,0) "@G" 5%44.....rc'8,5-- (3,0) "@A" ~-q02f;24-

Pilot
A/C



EAC	Jindrichuv Hradec, Czech Republic	2018	FORM B
Pilot ID #	Unlimited FreeUnknown2	Version F	Flight #

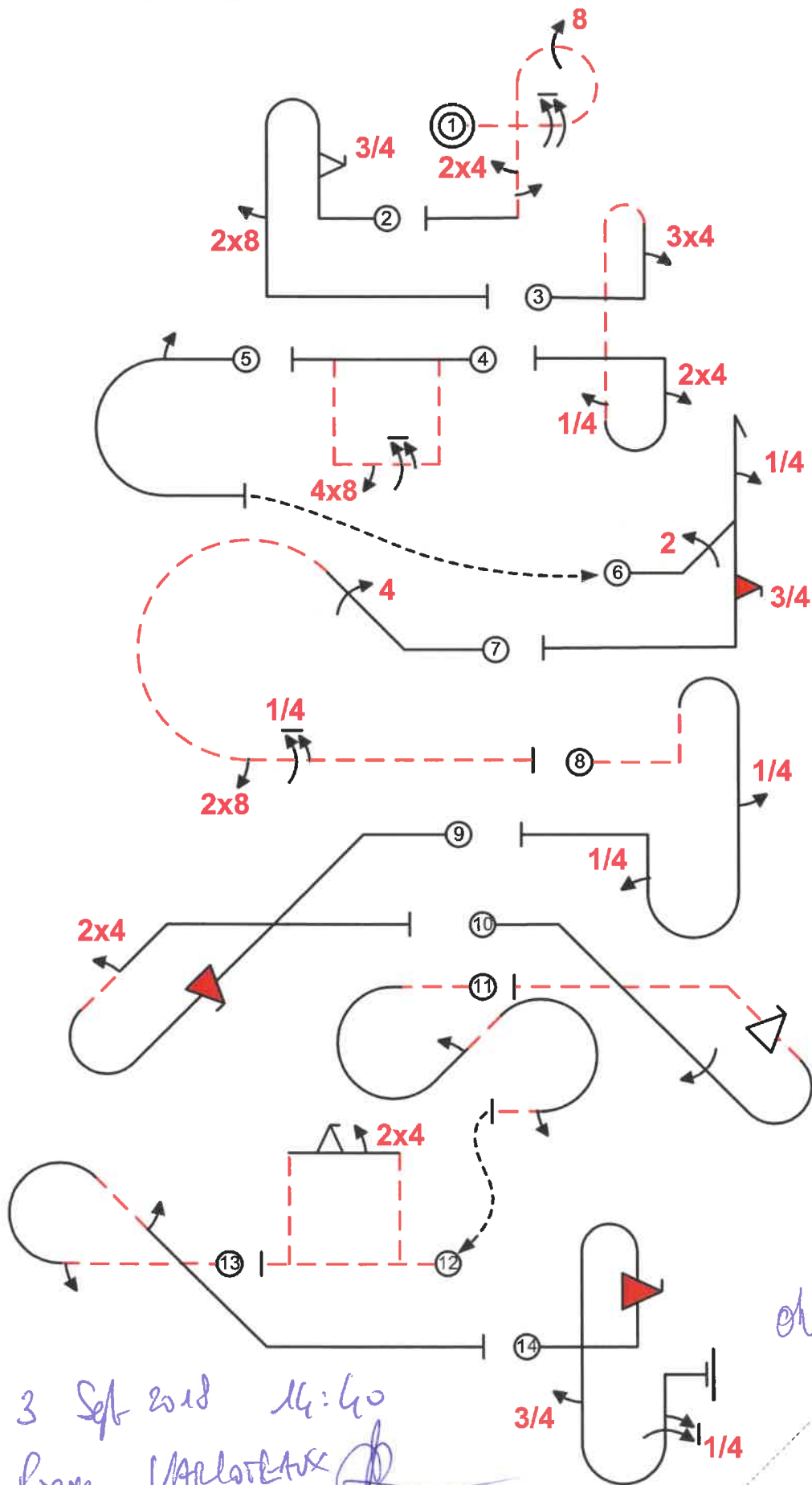

Fig	Code	Points	Order	Total	Notes
Fig 1	8.6.6.2	15	51	✓	
H	9.1.3.8	12			
	9.8.3.4	15			
	9.4.5.2	5			
	9.1.5.2	4			
Fig 2	8.4.1.1	13	31	✓	
E	9.9.1.3	15			
	9.8.5.1	3			
Fig 3	8.8.6.1	21	44	✓	
I	9.4.1.3	12			
	9.1.5.1	2			
	9.4.1.2	9			
Fig 4	7.4.3.3	18	35	✓	
J	9.8.3.2	7			
	9.1.3.6	10			
Fig 5	7.2.3.3	6	6		
L1	9.1.3.2	4			
Fig 6	5.3.1.1	18	48	✓	
F	9.2.2.4	11			
	9.1.1.1	6			
	9.10.5.3	13			
Fig 7	8.5.1.1	12	37	✓	
G	9.4.2.4	13			
	9.8.3.1	3			
	9.1.3.5	9			
Fig 8	8.8.7.2	21	6		
L2	9.1.5.1	2			
	9.1.1.1	6			
Fig 9	8.4.18.3	13	35	✓	
D	9.10.9.4	15			
	9.4.2.2	7			
Fig 10	8.4.17.3	11	34	✓	
C	9.1.4.4	8			
	9.9.7.4	15			
Fig 11	7.5.7.4	15	6		
L3	9.1.2.2	6			
	9.1.3.2	4			
Fig 12	7.4.3.2	19	35	✓	
A	9.9.3.2	11			
	9.4.3.2	5			
Fig 13	8.5.8.2	11	6		
L4	9.1.3.2	4			
	9.1.4.2	4			
Fig 14	8.8.2.1	19	58	✓	
B	9.10.6.4	19			
	9.1.5.3	6			
	9.1.1.5	14			
Total K 432					

3 Sep 2018 16:40
 From VARLOREAX

ok

pilot NAC
 A/C



EAC	Jindrichuv Hradec, Czech Republic	2018	FORM B
Pilot ID #	Unlimited FreeUnknown2	Version G	Flight #

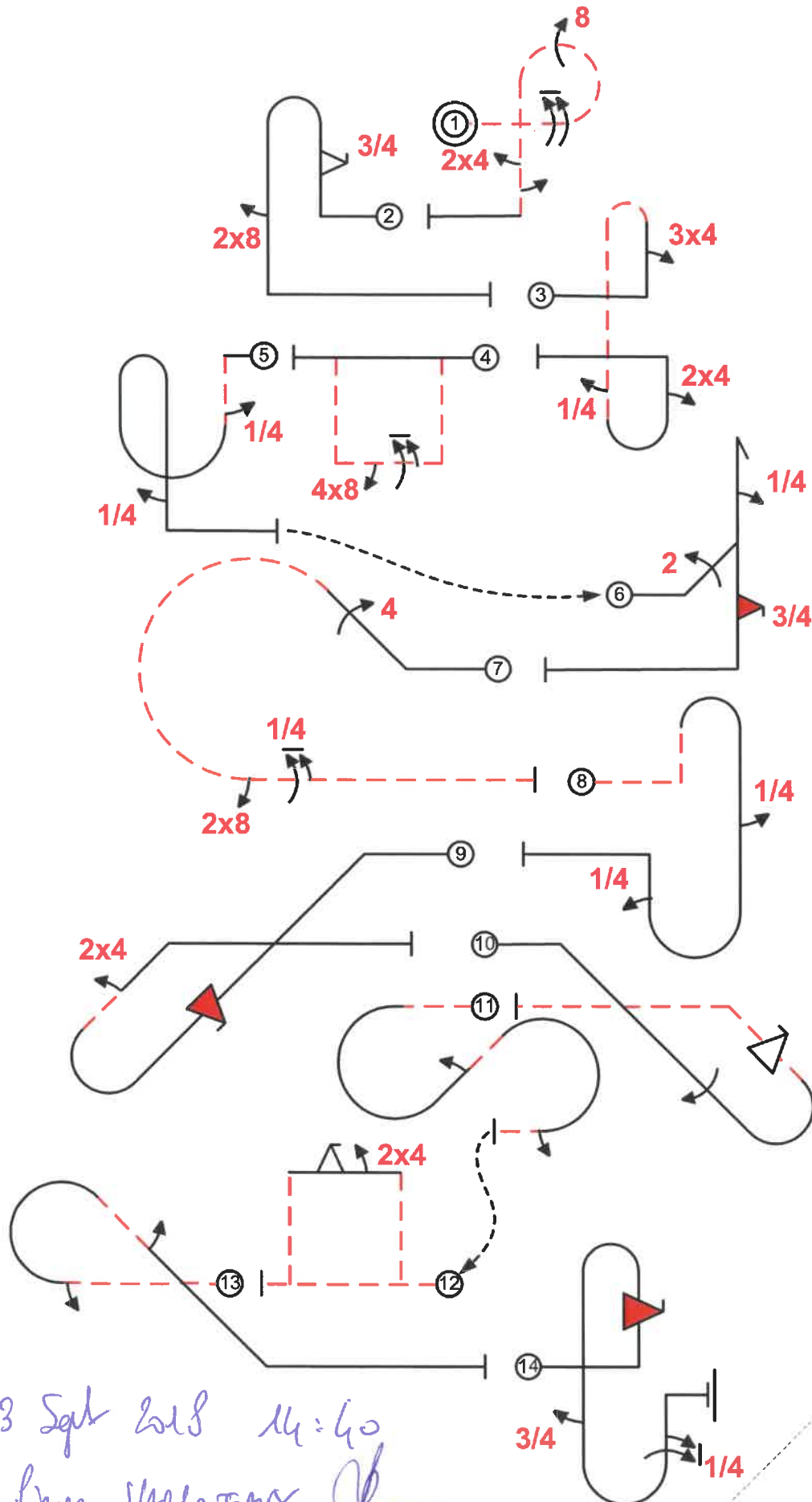

Fig 1 H RUS	8.6.6.2	15	51	✓
	9.1.3.8	12		
	9.8.3.4	15		
	9.4.5.2	5		
Fig 2 E ITA	8.4.1.1	13	31	✓
	9.9.1.3	15		
	9.8.5.1	3		
Fig 3 I HUN	8.8.6.1	21	44	✓
	9.4.1.3	12		
	9.1.5.1	2		
	9.4.1.2	9		
Fig 4 J ESP	7.4.3.3	18	35	✓
	9.8.3.2	7		
	9.1.3.6	10		
Fig 5 L1	8.8.8.3	19	6	✓
	9.1.5.1	2		
	9.1.5.1	2		
Fig 6 F ROU	5.3.1.1	18	48	✓
	9.2.2.4	11		
	9.1.1.1	6		
	9.10.5.3	13		
Fig 7 G FRA	8.5.1.1	12	37	✓
	9.4.2.4	13		
	9.8.3.1	3		
	9.1.3.5	9		
Fig 8 L2	8.8.7.2	21	6	✓
	9.1.5.1	2		
	9.1.1.1	6		
Fig 9 D CZE	8.4.18.3	13	35	✓
	9.10.9.4	15		
	9.4.2.2	7		
Fig 10 C POL	8.4.17.3	11	34	✓
	9.1.4.4	8		
	9.9.7.4	15		
Fig 11 L3	7.5.7.4	15	6	✓
	9.1.2.2	6		
	9.1.3.2	4		
Fig 12 A GER	7.4.3.2	19	35	✓
	9.9.3.2	11		
	9.4.3.2	5		
Fig 13 L4	8.5.8.2	11	6	✓
	9.1.3.2	4		
	9.1.4.2	4		
Fig 14 B SUI	8.8.2.1	19	58	✓
	9.10.6.4	19		
	9.1.5.3	6		
	9.1.1.5	14		
Total K 432				

Created Using Aresti 2016™ software. ACCassidy@aol.com

3 Sqft 2018 14=60
 Pierre VALLONIAUX

OK pilot
 NAC
 A/C



EAC 2018		H	Form B
Pilot ID	CIVA Unlimited Unknown2		Flight #

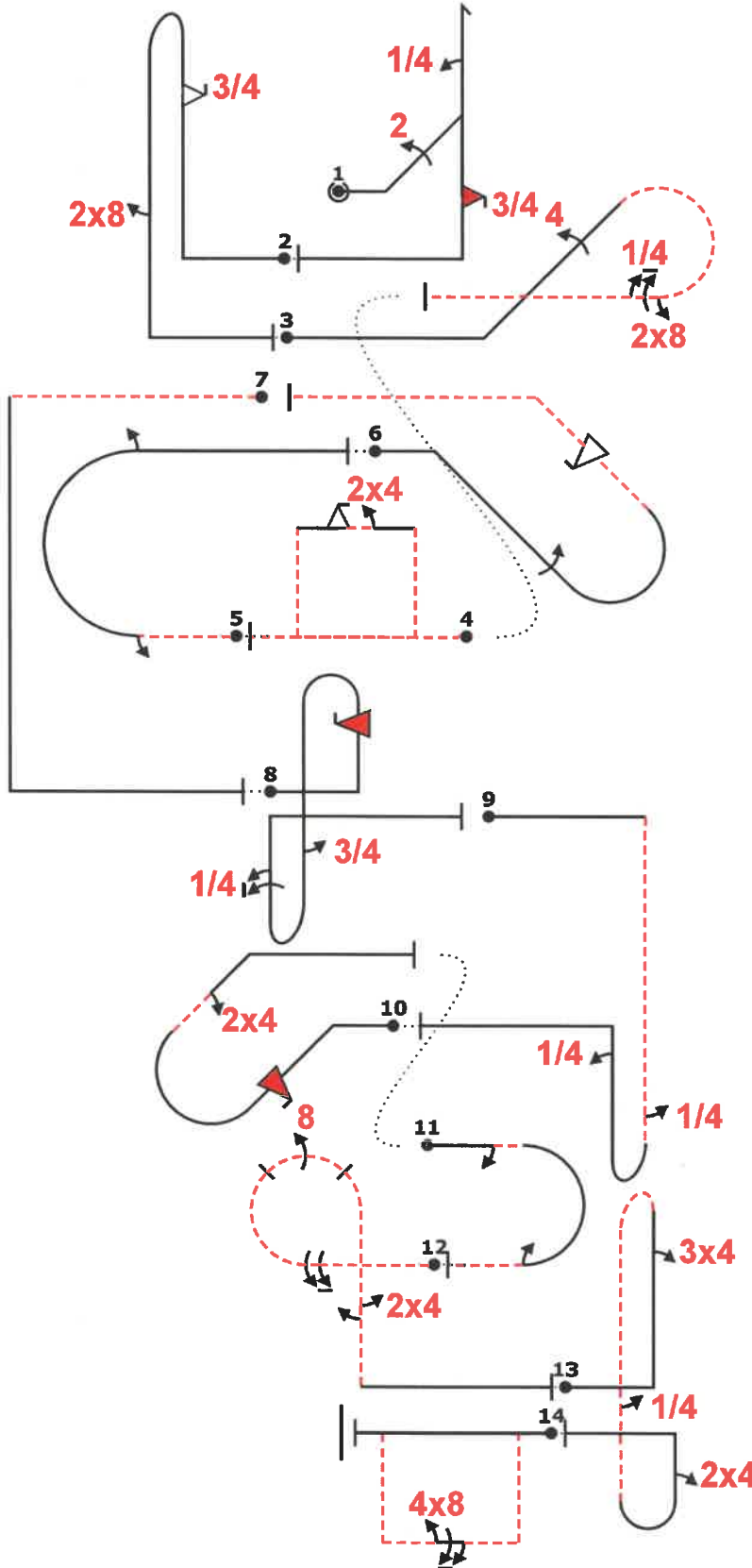

Power			
Fig 1 F	5.3.1.1	18	48 ✓
	9.2.2.4	11	
	9.1.1.1	6	
	9.10.5.3	13	
Fig 2 E	8.4.1.1	13	31 ✓
	9.9.1.3	15	
	9.8.5.1	3	
Fig 3 G	8.5.1.1	12	37 ✓
	9.4.2.4	13	
	9.8.3.1	3	
	9.1.3.5	9	
Fig 4 A	7.4.3.2	19	35 ✓
	9.9.3.2	11	
	9.4.3.2	5	
Fig 5 Add.	7.2.4.2	6	6 ✓
	9.1.3.2	4	
	9.1.3.2	4	
Fig 6 C	8.4.17.3	11	34 ✓
	9.1.4.4	8	
	9.9.7.4	15	
Fig 7 Add.	1.1.7.4	9	6 ✓
Fig 8 B	8.8.2.1	19	58 ✓
	9.10.6.4	19	
	9.1.5.3	6	
	9.1.1.5	14	
Fig 9 Add.	8.4.3.3	15	6 ✓
	9.1.5.1	2	
	9.1.1.1	6	
Fig 10 D	8.4.18.3	13	35 ✓
	9.10.9.4	15	
	9.4.2.2	7	
Fig 11 Add.	7.2.4.3	6	6 ✓
	9.1.3.2	4	
	9.1.3.2	4	
Fig 12 H	8.6.6.2	15	51 ✓
	9.1.3.8	12	
	9.8.3.4	15	
	9.4.5.2	5	
	9.1.5.2	4	
Fig 13 I	8.8.6.1	21	44 ✓
	9.4.1.3	12	
	9.1.5.1	2	
	9.4.1.2	9	
Fig 14 J	7.4.3.3	18	35 ✓
	9.8.3.2	7	
	9.1.3.6	10	
Total K = 432			

3 Sept 2018

M: 40

Pierre VALLONTEUX

[Signature] OK

Pilot
A/C

"@F" +22dh(4)'31f'+ (3,0) "@E" ~.,.3f'b...8..' + (-3,0) "@G" ~++44rc8,5~ (7,25) "@A" -qo'2f;24~ (3,0) "@L" 7% -2m2+~ (-2,0) "@C" ..11rdbf.--- "@L" ~-----1v.....+ (2,0) "@B" ifbb('3)'5+~ "@L" ~+.....'41b''4'+~ (2,0) "@O" ifindb'',24' (-3,14) "@L" 1 % ,2'1a,2~ (3,0) "@H" -9p(88)'24,2.+++ (-3,0) "@I" .',.34'pbb(.4.),24~ (3,0) "@J" i qo48,6A□A□A□A□



Jindrichuv Hradec		I	Form B
Pilot ID	CIVA Unlimited Unknown2		Flight #

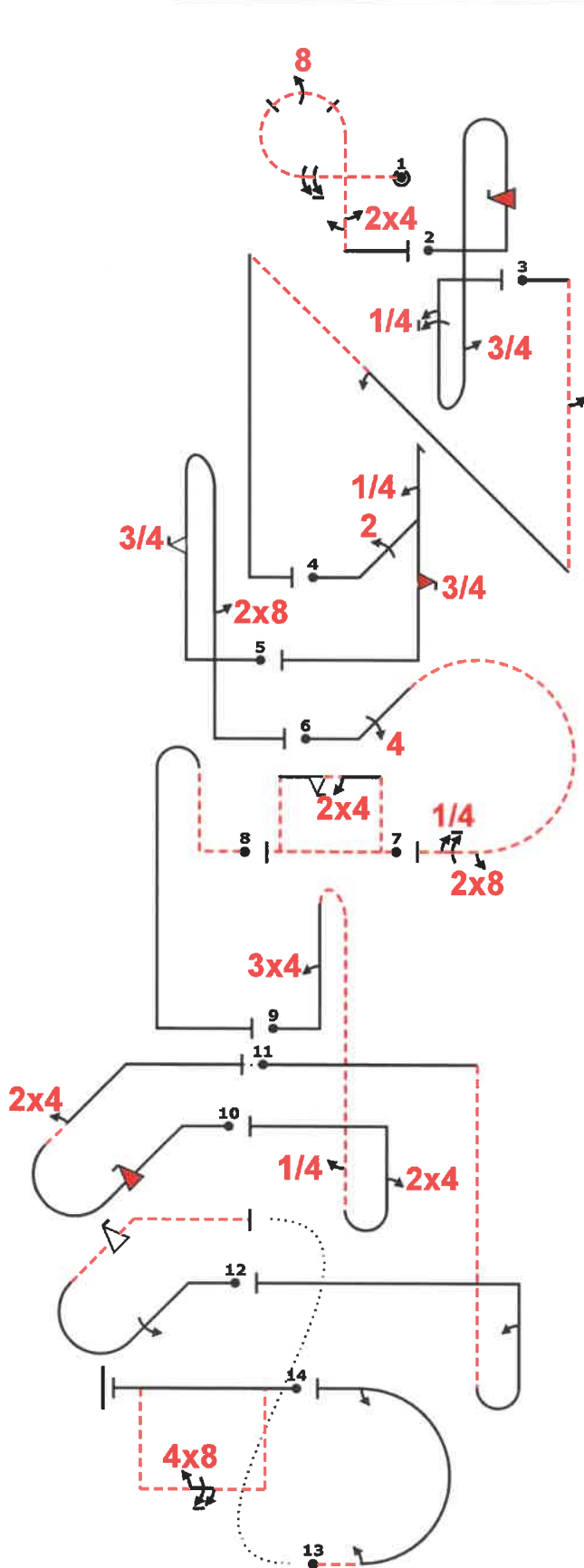

Power			
Fig 1 H	8.6.6.2	15	51
	9.1.3.8	12	
	9.8.3.4	15	
	9.4.5.2	5	
	9.1.5.2	4	
Fig 2 B	8.8.2.1	19	58
	9.10.6.4	19	
	9.1.5.3	6	
	9.1.1.5	14	
Fig 3 Add.	1.3.16.3	21	6
	9.1.5.2	4	
	9.1.2.2	6	
Fig 4 F	5.3.1.1	18	48
	9.2.2.4	11	
	9.1.1.1	6	
	9.10.5.3	13	
Fig 5 E	8.4.1.1	13	31
	9.9.1.3	15	
	9.8.5.1	3	
Fig 6 G	8.5.1.1	12	37
	9.4.2.4	13	
	9.8.3.1	3	
	9.1.3.5	9	
Fig 7 A	7.4.3.2	19	35
	9.9.3.2	11	
	9.4.3.2	5	
Fig 8 Add.	8.4.4.2	14	6
Fig 9 I	8.8.6.1	21	44
	9.4.1.3	12	
	9.1.5.1	2	
	9.4.1.2	9	
Fig 10 D	8.4.18.3	13	35
	9.10.9.4	15	
	9.4.2.2	7	
Fig 11 Add.	8.4.3.3	15	6
	9.1.1.2	8	
Fig 12 C	8.4.17.3	11	34
	9.1.4.4	8	
	9.9.7.4	15	
Fig 13 Add.	7.2.4.2	6	6
	9.1.3.2	4	
	9.1.3.2	4	
Fig 14 J	7.4.3.3	18	35
	9.8.3.2	7	
	9.1.3.6	10	
Total K = 432			

3 Sept. 2018
 14:40
 Pierre Unklovaux
 [Signature]
 OK

ed "@H" -9p(88)24,2~ "@B" ~if."bb(...'3').''5' "@L" ...''2...''in(...'2....)..... "oF" 22dh('4)''3if.'''++ "@E" 1% /. '3f.'b.' '8..' "
 @G" 13% '+' ,44" rc8,5- "@A" -1% -go,2f;24- "@L" ...''-b.....+ "@I" ...''+34.' 'pbb(...'4)',24'+~+ "@O" ',if'indb''2
 4..+ (-2,0) "@L" ~++++.....''1b2++++~+~+ "@C" 11rdbf- (2,33) "@L" 11% ~''2m2+~ "@J" 2% iqa48,6

Pilot
 A/C



Pilot ID		J	Form B
CIVA Unlimited Programme3			Flight #

wind/vent

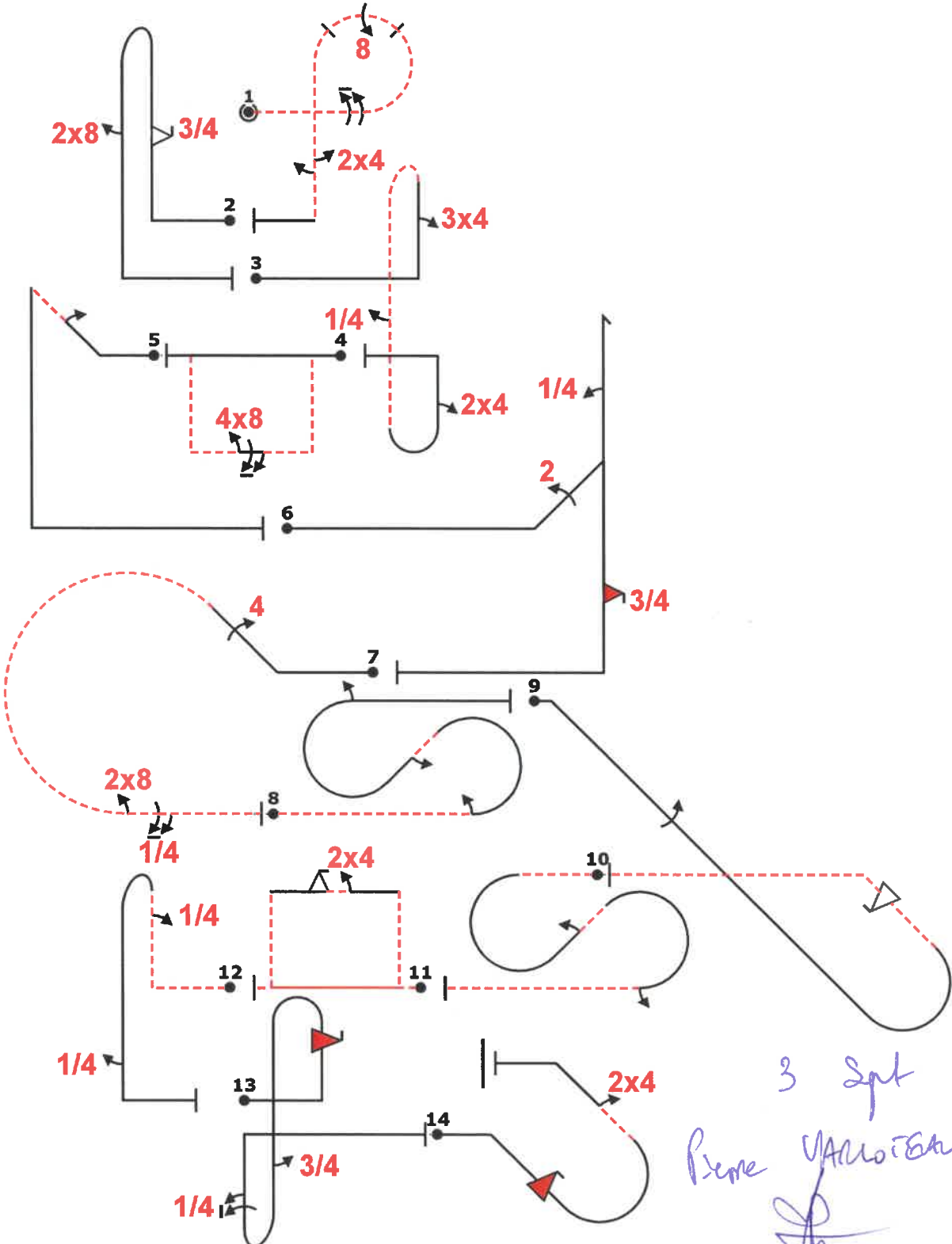

Power			
Fig 1 H	8.6.6.2	15	51 ✓
	9.1.3.8	12	
	9.8.3.4	15	
	9.4.5.2	5	
	9.1.5.2	4	
Fig 2 E	8.4.1.1	13	31 ✓
	9.9.1.3	15	
	9.8.5.1	3	
Fig 3 I	8.8.6.1	21	44 ✓
	9.4.1.3	12	
	9.1.5.1	2	
	9.4.1.2	9	
Fig 4 J	7.4.3.3	18	35 ✓
	9.8.3.2	7	
	9.1.3.6	10	
Fig 5 Add.	1.2.3.1	12	6 ✓
	9.1.2.2	6	
Fig 6 F	5.3.1.1	18	48 ✓
	9.2.2.4	11	
	9.1.1.1	6	
	9.10.5.3	13	
Fig 7 G	8.5.1.1	12	37 ✓
	9.4.2.4	13	
	9.8.3.1	3	
	9.1.3.5	9	
Fig 8 Add.	7.5.8.2	15	6 ✓
	9.1.3.2	4	
	9.1.4.2	4	
	9.1.3.2	4	
Fig 9 C	8.4.17.3	11	34 ✓
	9.1.4.4	8	
	9.9.7.4	15	
Fig 10 Add.	7.5.7.4	15	6 ✓
	9.1.2.2	6	
	9.1.3.2	4	
Fig 11 A	7.4.3.2	19	35 ✓
	9.9.3.2	11	
	9.4.3.2	5	
Fig 12 Add.	8.4.4.2	14	6 ✓
	9.1.1.1	6	
	9.1.5.1	2	
Fig 13 B	8.8.2.1	19	58 ✓
	9.10.6.4	19	
	9.1.5.3	6	
	9.1.1.5	14	
Fig 14 D	8.4.18.3	13	35 ✓
	9.10.9.4	15	
	9.4.2.2	7	
Total K = 432			

3 Spt 2018 14:40
 Pierre YARROUX
 OK

Pilot _____
 A/C _____

@@H -9p(B8)24,2'~ "@E" ,3f.'b,8...'+ "@I" ~+,34'pbb(.4.''),24 "@J" iqa48,6 (3,0) "@L" ,2t...++++ "@F" ~++++22dh('14'').. '3if.'+
 +++ "@G" 15% '+ ,44'.....rc8,5-..... [-3,0] "@L" ~2ac(2)2+... "@C" '1.....irdbf---- [3,0] "@L" iac(2)2-
 "@A" -qozf;24- "@L" -,4b... ,4' "@B" 2> ,1fbb('13)5'+++ (-3,0) "@O" ifirdb' ,24,.....



K		Form B
Pilot ID	CIVA Unlimited Programme3	Flight #

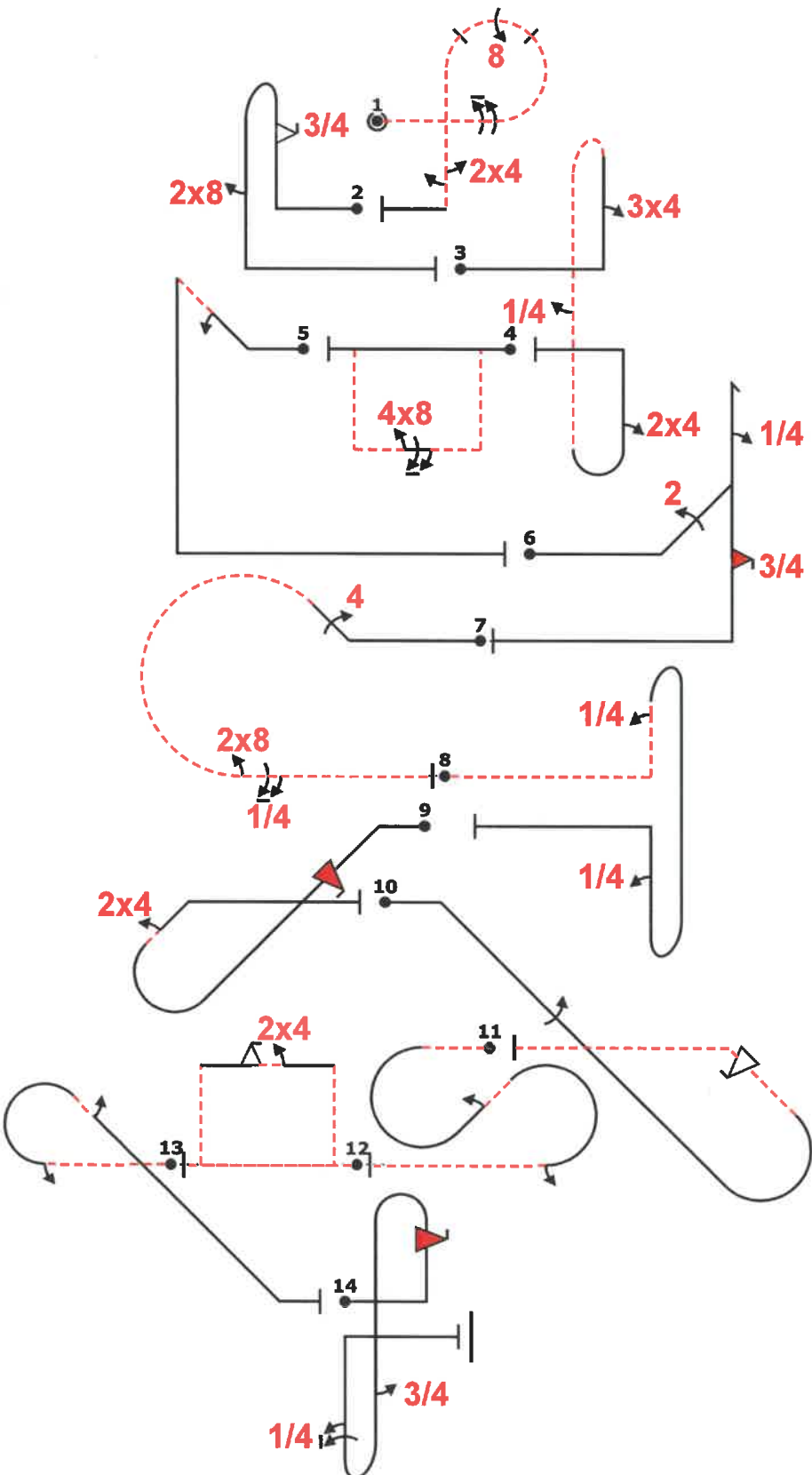

Power			
Fig 1 H	8.6.6.2	15	51
	9.1.3.8	12	
	9.8.3.4	15	
	9.4.5.2	5	
	9.1.5.2	4	
Fig 2 E	8.4.1.1	13	31
	9.9.1.3	15	
	9.8.5.1	3	
Fig 3 I	8.8.6.1	21	44
	9.4.1.3	12	
	9.1.5.1	2	
	9.4.1.2	9	
Fig 4 J	7.4.3.3	18	35
	9.8.3.2	7	
	9.1.3.6	10	
Fig 5 Add.	1.2.3.1	12	6
	9.1.2.2	6	
Fig 6 F	5.3.1.1	18	48
	9.2.2.4	11	
	9.1.1.1	6	
	9.10.5.3	13	
Fig 7 G	8.5.1.1	12	37
	9.4.2.4	13	
	9.8.3.1	3	
	9.1.3.5	9	
Fig 8 Add.	8.8.7.2	21	6
	9.1.1.1	6	
	9.1.1.1	6	
Fig 9 D	8.4.18.3	13	35
	9.10.9.4	15	
	9.4.2.2	7	
Fig 10 C	8.4.17.3	11	34
	9.1.4.4	8	
	9.9.7.4	15	
Fig 11 Add.	7.5.7.4	15	6
	9.1.2.2	6	
	9.1.3.2	4	
Fig 12 A	7.4.3.2	19	35
	9.9.3.2	11	
	9.4.3.2	5	
Fig 13 Add.	8.5.8.2	11	6
	9.1.3.2	4	
	9.1.4.2	4	
Fig 14 B	8.8.2.1	19	58
	9.10.6.4	19	
	9.1.5.3	6	
	9.1.1.5	14	
Total K = 432			

3 Sept 2018
 dh: 40
 Pierre VALLÉE
 OK

Pilot
 AC

"@H" -9p(88)24,2~ "@E",3fb,8'+++ "@I" ~+34.pbb('4..'),24'~ "@J" 1qo48,6 "@L" 2t.....'+++++ "@F" ++22dh(,4)'3if.'++++ (3,0) "@G" 10% ~.....,44'.....rc8,5-..... [-3,0] "@L" ~---4bb(''),4+~ "@D" 2> -2% '1f.....1rdb''24'~ "@C" ..'1.....'1rdbf--- "@L" ~.....1ac(2)2- (3,0) "@A" -qo2f;24- (3,0) "@L" -2% -'2c2.....' "@B",1fbb('3)5.+



EAC 2018		L	Form B
Pilot ID	CIVA Unlimited Unknown2		Flight #

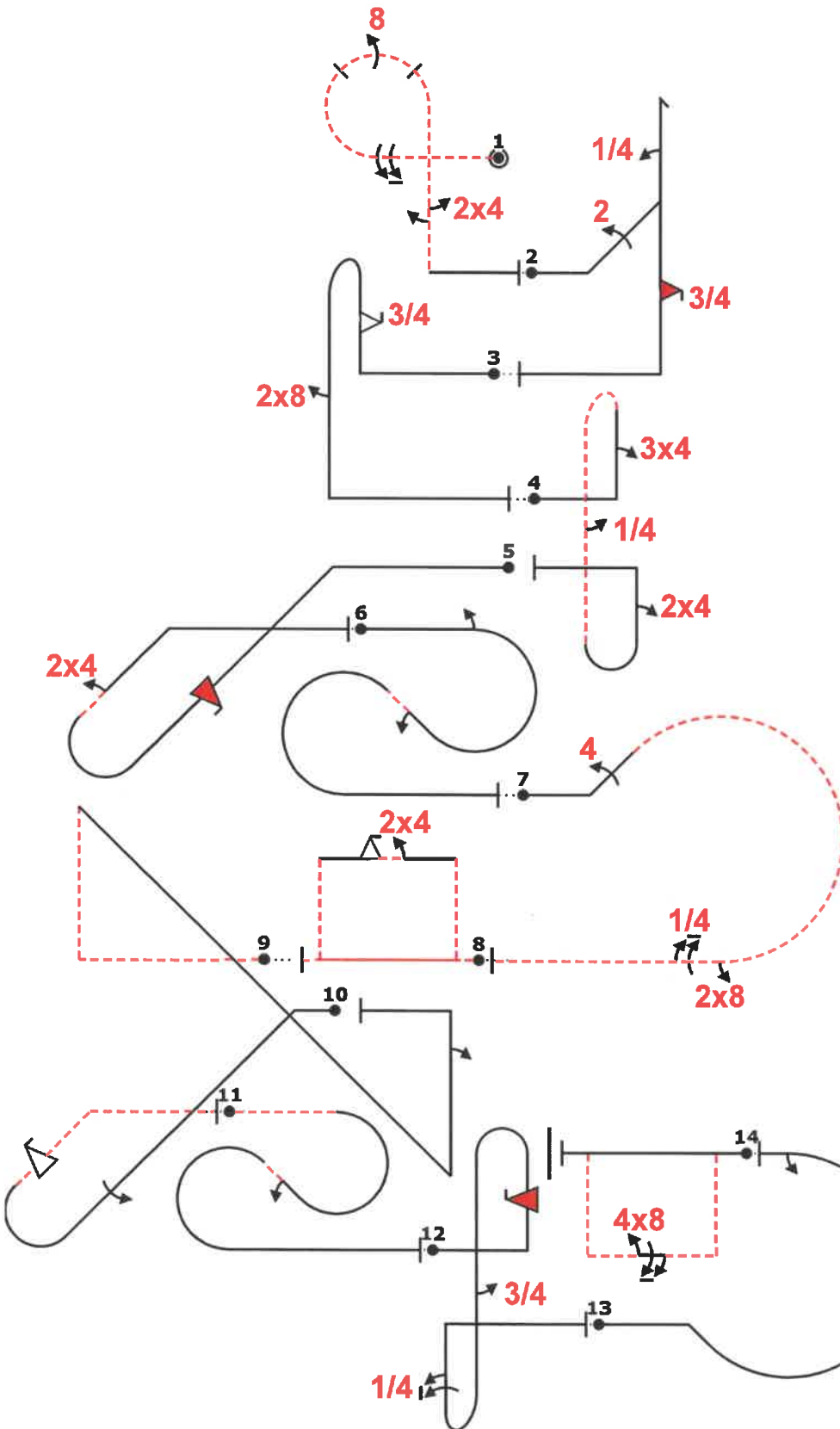

Power			
Fig 1 H	8.6.6.2	15	51 ✓
	9.1.3.8	12	
	9.8.3.4	15	
	9.4.5.2	5	
	9.1.5.2	4	
Fig 2 F	5.3.1.1	18	48 ✓
	9.2.2.4	11	
	9.1.1.1	6	
	9.10.5.3	13	
Fig 3 E	8.4.1.1	13	31 ✓
	9.9.1.3	15	
	9.8.5.1	3	
Fig 4 I	8.8.6.1	21	44 ✓
	9.4.1.3	12	
	9.1.5.1	2	
	9.4.1.2	9	
Fig 5 D	8.4.18.3	13	35 ✓
	9.10.9.4	15	
	9.4.2.2	7	
Fig 6 Add.	7.5.5.3	15	6 ✓
	9.1.3.2	4	
	9.1.2.2	6	
Fig 7 G	8.5.1.1	12	37 ✓
	9.4.2.4	13	
	9.8.3.1	3	
	9.1.3.5	9	
Fig 8 A	7.4.3.2	19	35 ✓
	9.9.3.2	11	
	9.4.3.2	5	
Fig 9 Add.	1.3.10.2	24	6 ✓
	9.1.1.2	8	
Fig 10 C	8.4.17.3	11	34 ✓
	9.1.4.4	8	
	9.9.7.4	15	
Fig 11 Add.	7.5.2.4	15	6 ✓
	9.1.2.2	6	
Fig 12 B	8.8.2.1	19	58 ✓
	9.10.6.4	19	
	9.1.5.3	6	
	9.1.1.5	14	
Fig 13 Add.	8.5.3.3	10	6 ✓
	9.1.3.2	4	
Fig 14 J	7.4.3.3	18	35 ✓
	9.8.3.2	7	
	9.1.3.6	10	
Total K = 432			

3 Sept 2018
16:40
Pierre CHLOTTEAU

[Signature]
OK
Pilot
A/C

ed "@H" -9p(88)24,2''+ (-3,0) "@F" 22dh(4).3if. "+ (2,0) "@E" + "3f'b''',8.'++++ (-2,0) "@I" ',34''pbb(''4.'')',24'~ "@D" -3% +++++..
...if...indb' 24.'++++ (-3,0) "@L" 2% +2lac('2')' + (-2,0) "@G" 14% + 44' rc8,5- (3,0) "@A" -qo2f;24
- (1,0) "@L" ~~~~~'pn(.....)'',2' + "@C" -3%1.'indb' f.'~ (-3,0) "@L"-lac('2')' + (-3,0) "@B" ~if''bb('3.'')
5~ (-3,0) "@L" 12% + 1nc2+ (3,0) "@J" 1qo48,6



EAC 2018		M	Form B
Pilot ID	CIVA Unlimited Unknown2		Flight #

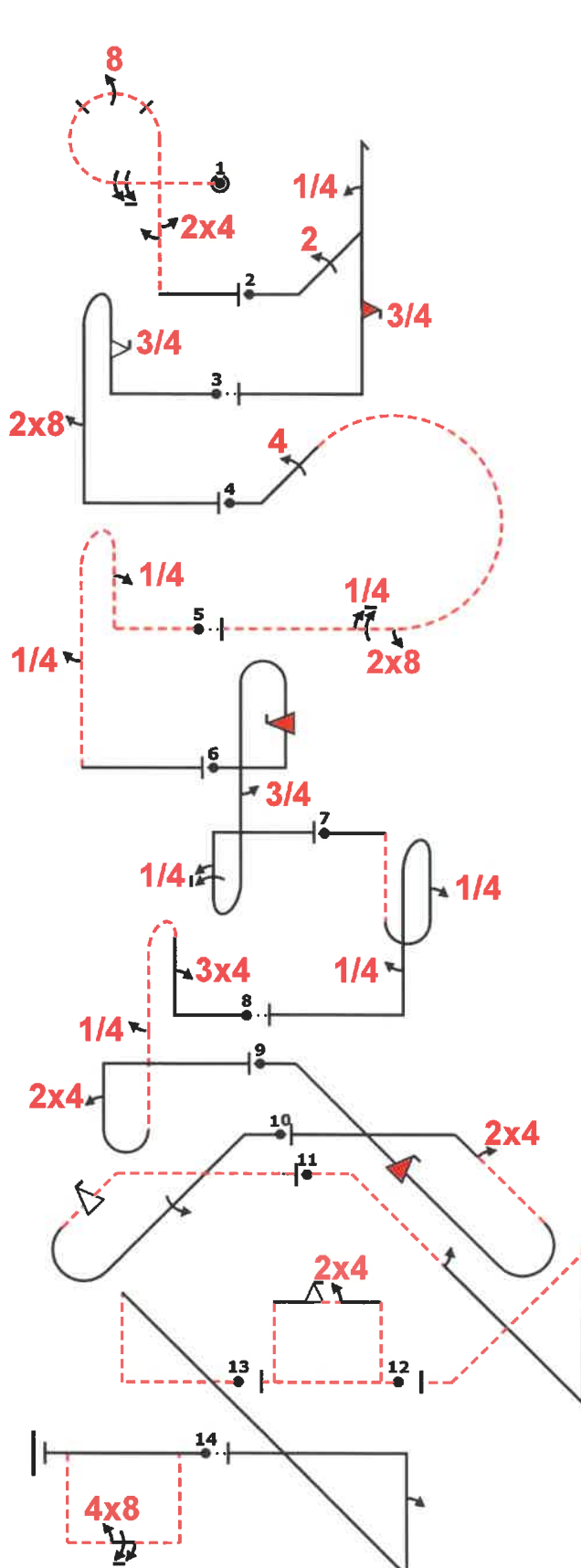

Power			
Fig 1 H	8.6.6.2	15	51 ✓
	9.1.3.6	12	
	9.8.3.4	15	
	9.4.5.2	5	
	9.1.5.2	4	
Fig 2 F	5.3.1.1	18	48 ✓
	9.2.2.4	11	
	9.1.1.1	6	
	9.10.5.3	13	
Fig 3 E	8.4.1.1	13	31 ✓
	9.9.1.3	15	
	9.8.5.1	3	
Fig 4 G	8.5.1.1	12	37 ✓
	9.4.2.4	13	
	9.8.3.1	3	
	9.1.3.5	9	
Fig 5 Add.	8.4.2.2	17	6 ✓
	9.1.1.1	6	
	9.1.5.1	2	
Fig 6 B	8.8.2.1	19	58 ✓
	9.10.6.4	19	
	9.1.5.3	6	
	9.1.1.5	14	
Fig 7 Add.	8.8.8.3	19	6 ✓
	9.1.1.1	6	
	9.1.5.1	2	
Fig 8 I	8.8.6.1	21	44 ✓
	9.4.1.3	12	
	9.1.5.1	2	
	9.4.1.2	9	
Fig 9 D	8.4.18.3	13	35 ✓
	9.10.9.4	15	
	9.4.2.2	7	
Fig 10 C	8.4.17.3	11	34 ✓
	9.1.4.4	8	
	9.9.7.4	15	
Fig 11 Add.	1.3.2.4	19	6 ✓
	9.1.4.2	4	
Fig 12 A	7.4.3.2	19	35 ✓
	9.9.3.2	11	
	9.4.3.2	5	
Fig 13 Add.	1.3.10.2	24	6 ✓
	9.1.1.2	8	
Fig 14 J	7.4.3.3	18	35 ✓
	9.8.3.2	7	
	9.1.3.6	10	
Total K = 432			

3 Sept 2018
16:40
Prévue VAPLOTORUK
OK

ed "@H" -9p(88)24,2,+ (-3,0) "@F" 22dh(4).3if.' '++ (2,0) "@E" +',.3f'b.,8,++ (-3,0) "@G" 14% "++ "44" "rc8,5- (2,0) 2%
"@L" -',,4pb',4,'+ (-3,0) "@B" 'if''bb(3.'')5'+ (-3,0) "@L" +',,ibb(' '4')..',4++ (2,0) "@I" ',34" 'pbb(' '4.'')'24'++ (-3,0) "@D"
-3%'lf.....irdb.,,24'+++ (3,0) "@C" -3% ..'1....'irdb'f'----- (-3,0) -1% "@L" -....'2...'lw(' '.)'...' "@A" -1% -qo2f;24- "@L" --
-'pn(.....)',,2+++ (2,0) "@J" 'iqo48,6

Pilot
A/C

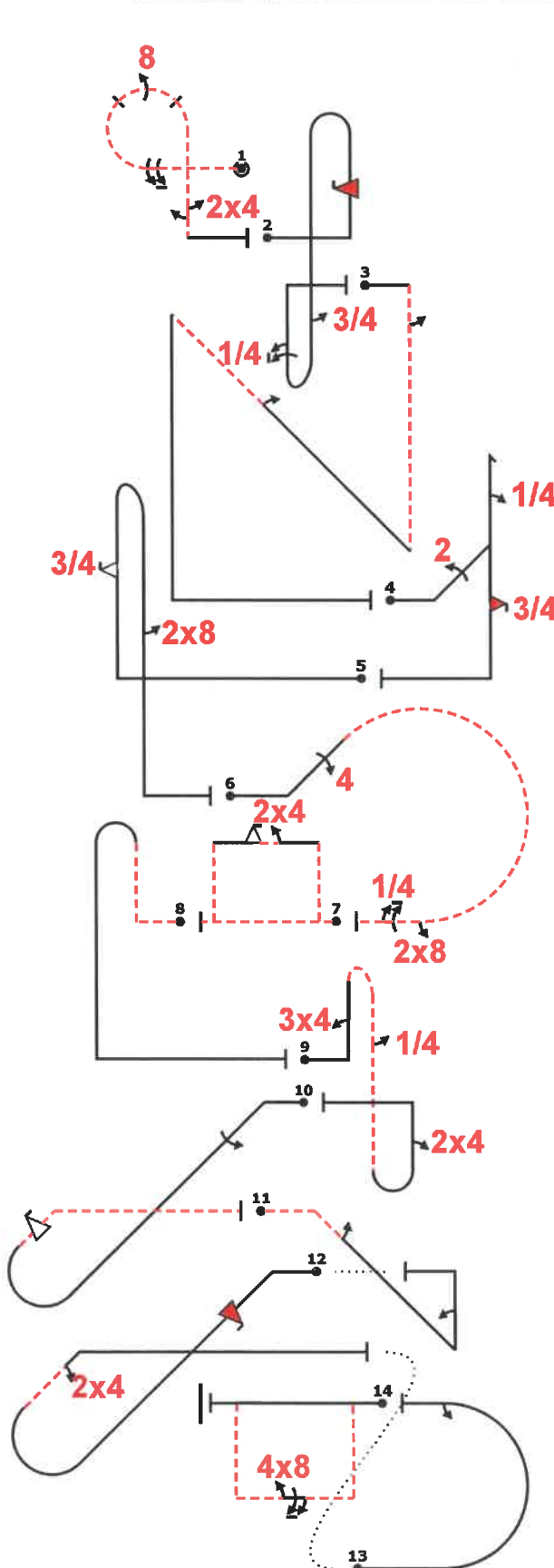

Power				
Fig 1 H	8.6.6.2	15	51	✓
	9.1.3.8	12		
	9.8.3.4	15		
	9.4.5.2	5		
Fig 2 B	8.8.2.1	19	58	✓
	9.10.5.4	19		
	9.1.5.3	6		
Fig 3 Add.	1.3.16.3	21	6	✓
	9.1.5.2	4		
	9.1.2.2	6		
Fig 4 F	5.3.1.1	18	48	✓
	9.2.2.4	11		
	9.1.1.1	6		
	9.10.5.3	13		
Fig 5 E	8.4.1.1	13	31	✓
	9.9.1.3	15		
	9.8.5.1	3		
Fig 6 G	8.5.1.1	12	37	✓
	9.4.2.4	13		
	9.8.3.1	3		
	9.1.3.5	9		
Fig 7 A	7.4.3.2	19	35	✓
	9.9.3.2	11		
	9.4.3.2	5		
Fig 8 Add.	8.4.4.2	14	6	✓
Fig 9 I	8.8.6.1	21	44	✓
	9.4.1.3	12		
	9.1.5.1	2		
	9.4.1.2	9		
Fig 10 C	8.4.17.3	11	34	✓
	9.1.4.4	8		
	9.9.7.4	15		
Fig 11 Add.	1.2.4.4	13	6	✓
	9.1.4.2	4		
	9.1.1.2	8		
Fig 12 D	8.4.18.3	13	35	✓
	9.10.9.4	15		
	9.4.2.2	7		
Fig 13 Add.	7.2.2.1	6	6	✓
	9.1.3.2	4		
Fig 14 J	7.4.3.3	18	35	✓
	9.8.3.2	7		
	9.1.3.6	10		
Total K = 432				

3 Sept 2018
M=40

Pierre VARLOTEUX
OK

Pilot
A/C